



Corso di Dispositivi Elettronici - A. A. 2004/2005

Basics of RF Devices

Mainstream electronics ***(processors, ASICs, memories)***

Semiconductors

- Si

Transistor Types

- MOSFETs
- For a few applications BJTs

- Governed by Moore's Law
- Increasing number of devices per chip
- Scaling (decreasing device size)
- CD < 1 μm around 1987 (commercially)
- Si MOSFET dominates

RF electronics

Semiconductors

- **III-V compounds based on GaAs and InP**
- **Si and SiGe**
- **Wide bandgap materials (SiC and III-nitrides)**

Transistor Types

- **MESFET - Metal Semiconductor FET**
- **HEMT - High Electron Mobility Transistor**
- **MOSFET - Metal Oxide Semiconductor FET**
- **HBT - Heterojunction Bipolar Transistor**
- **BJT - Bipolar Junction Transistor**

RF electronics

- Moore's Law is not an issue
- Integration is less important
- Traditionally a submicron technology
- Commercial devices

1980 0.5 - 2 μm

1982 0.25 - 1 μm

2004 0.05 - 0.5 μm

Mainstream electronics

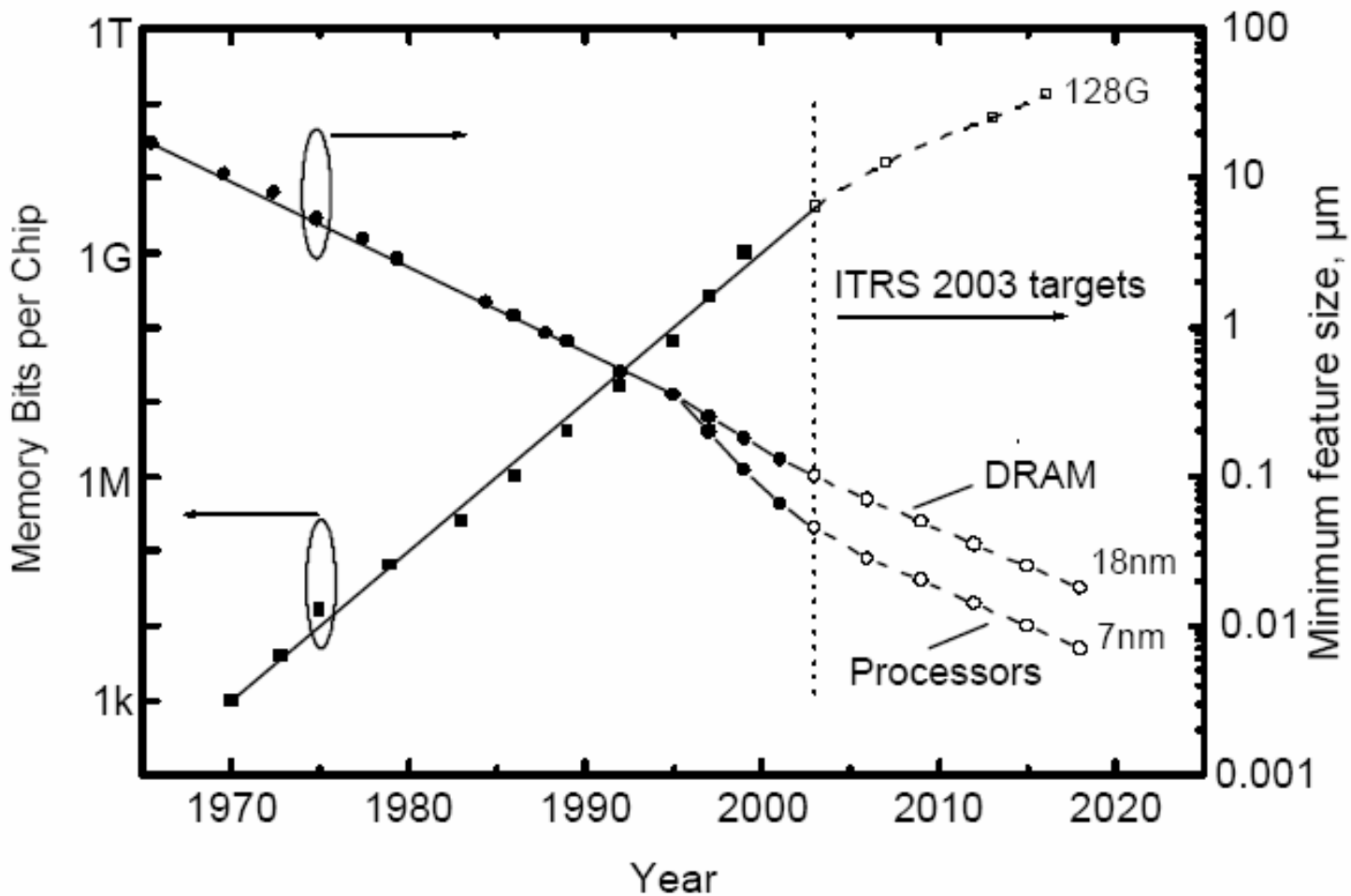

Mainstream electronics

Evolution of Intel Processors

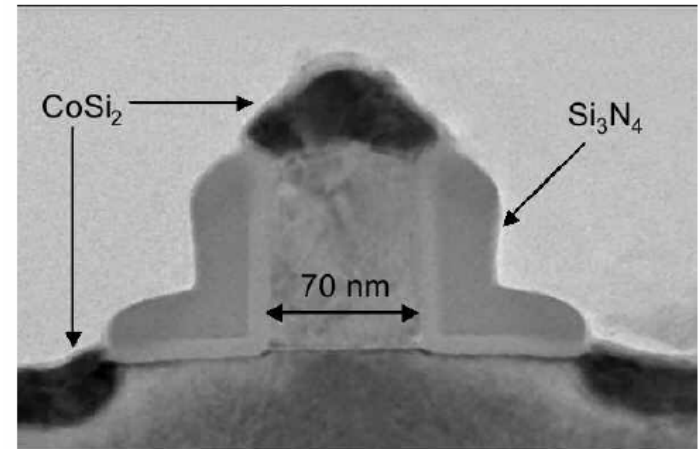
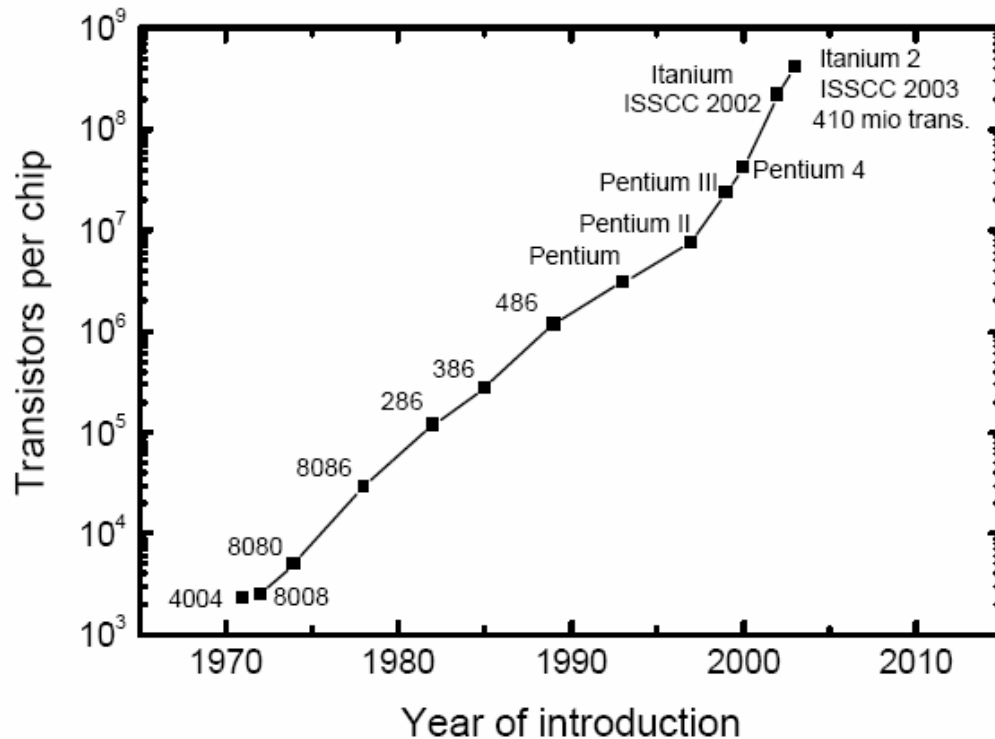

Intel MOSFET with 70 nm gate

More than 40 Mio. transistors of this type are integrated on a single Pentium 4 chip.

Mainstream electronics is on the way to nanoelectronics

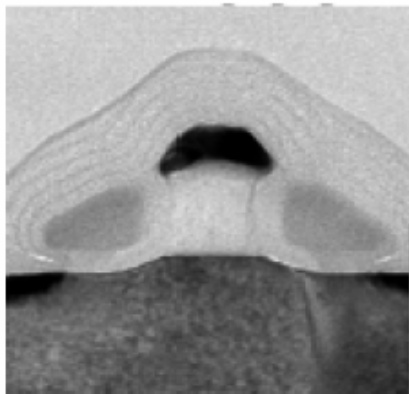

IEDM 2000
Intel 30nm

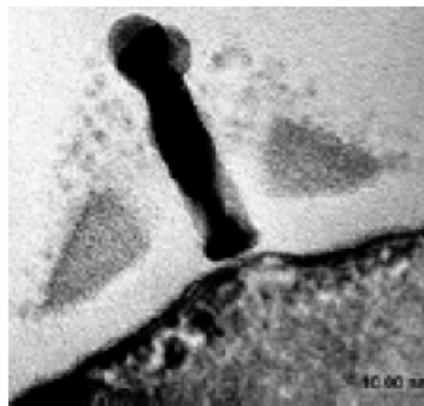

DRC 2003
Intel 10nm

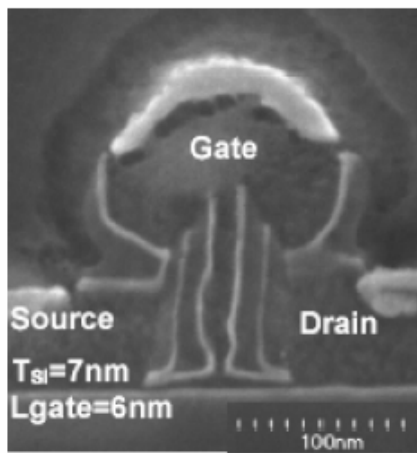

IEDM 2002
IBM 6nm

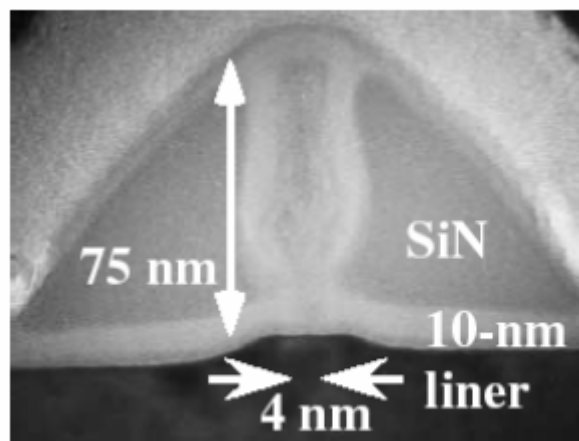

IEDM 2003
NEC 5nm

Intel's new Tri-Gate MOSFET

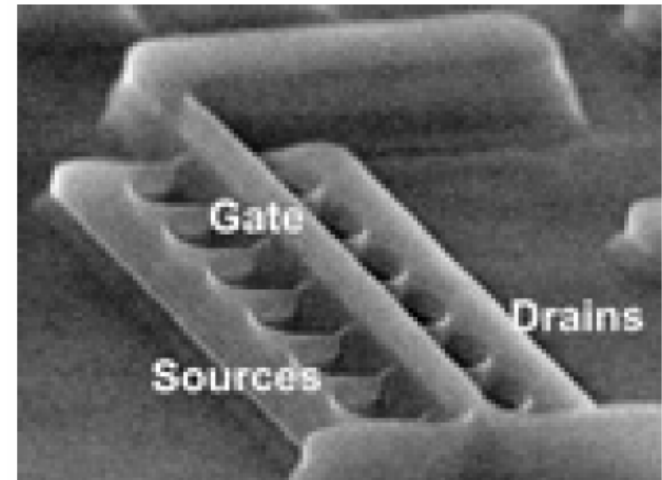
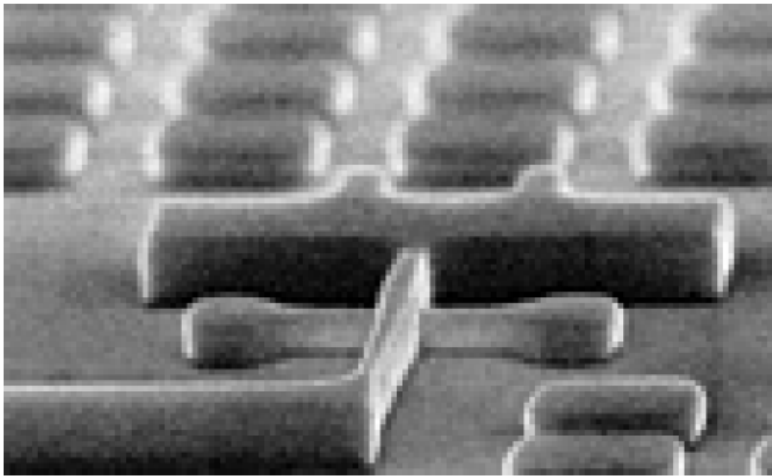

- Smaller and smaller devices
- New MOSFET concepts
- But: Si still dominates
MOSFET still dominates

Market Trends

- **by 1980** Only military applications, RF is synonymous with mysterious. Philosophy: Performance at any price.
- **1980s-90s** Increasing number of consumer applications
- **Late 1990s** Clear shift from military to consumer applications, explosion of the market for mobile communications. Now: reasonable performance at lowest price.
- **2001** Considerable turbulences, layoffs. There are no markets with unlimited growth!
- **2003/2004** Recovery. In the medium and long term, RF electronics will still grow dynamically. New applications will be introduced.

Market Trends

Applications

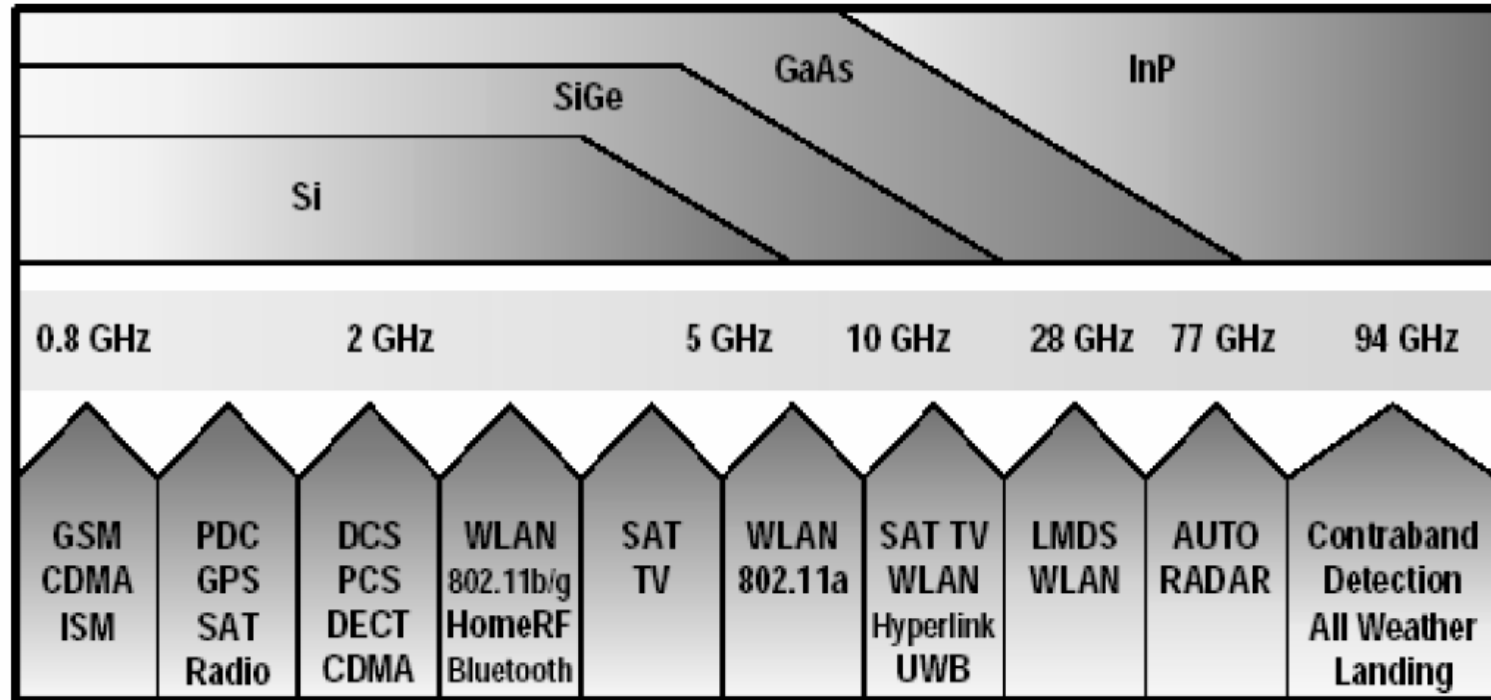

Taken from: ITRS 2003 Edition.

Chapter *Radio Frequency and Analog/Mixed-Signal Technologies for Wireless Communications*

Acronyms

- **GSM** Global System for Mobile Communications
- **CDMA** Code-Division Multiple Access
- **ISM** Industrial, Scientific and Medical (frequency bands)
- **PDC** Personal digital cellular
- **GPS** Global Positioning System (Satellite)
- **DCS** Digital Communication System
- **PCS** Personal Communications system
- **DECT** Digital European Cordless Telephone/Telecommunications
- **WLAN** Wireless Local Areal Network
- **UWB** Ultra-Wideband

Transistor Concepts I

Two basic transistor concepts

- **FETs (Field-Effect Transistor)**
The output current (mainly a drift current) is controlled by a perpendicular field.
The conductivity of the channel is varied by changing the potential of a control electrode (gate).
 - MESFETs (Metal-Semiconductor FET)
 - HEMTs (High Electron Mobility Transistor)
 - MOSFETs (Metal-Oxide-Semiconductor FET)
- **Bipolar transistors**
The output current (mainly a diffusion current) is controlled by the voltage across a pn junction.
The carrier injection is varied by changing the voltage across the junction.
 - BJT (Bipolar Junction Transistor)
 - HBT (Heterojunction Bipolar Transistor).

Transistor Concepts I - FETs

A FET in general

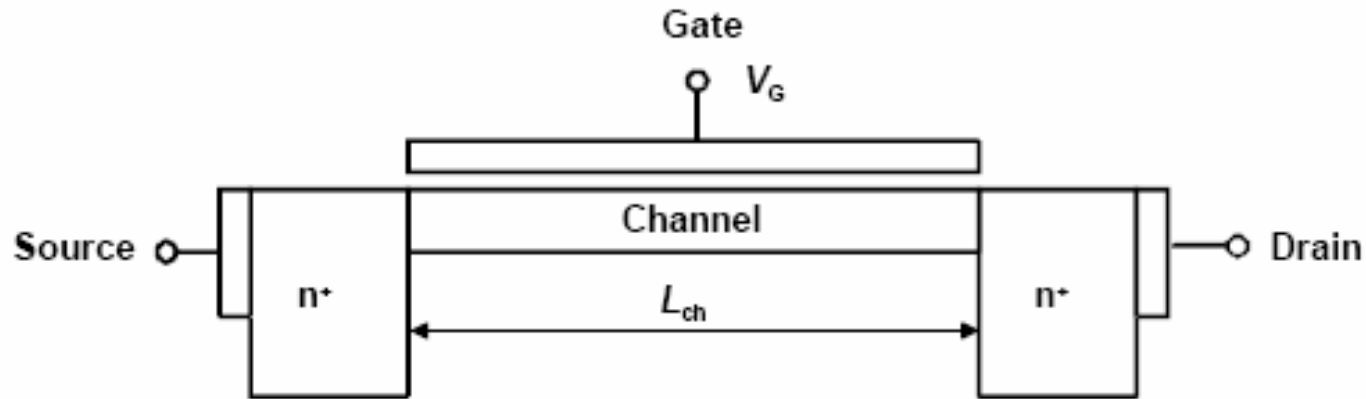

RF FETs use n-channels.
A more positive gate voltage increases the number of carriers (electrons) in the channel

Transistor Concepts I - FETs

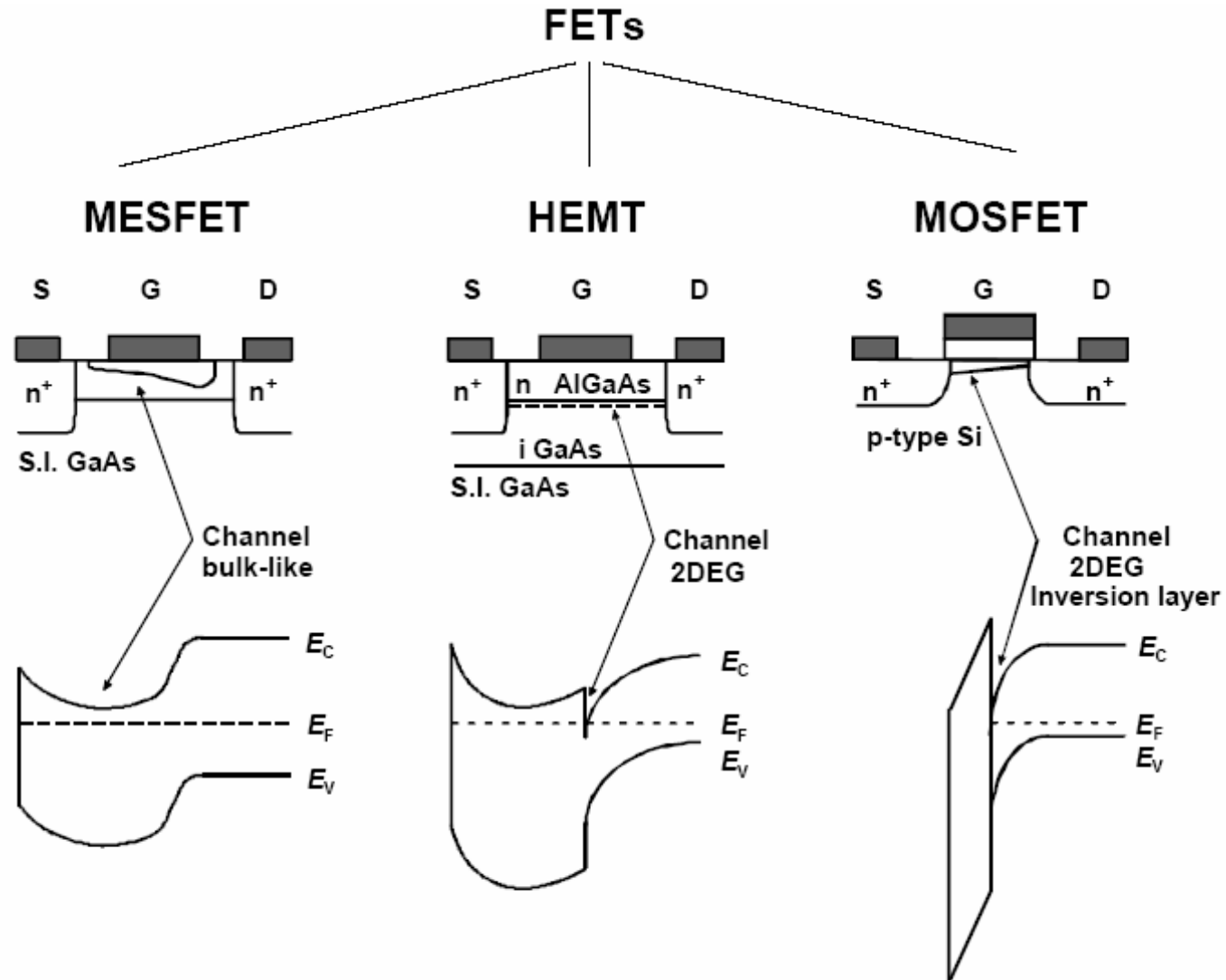

Transistor Concepts I - Bipolars

A bipolar transistor in general

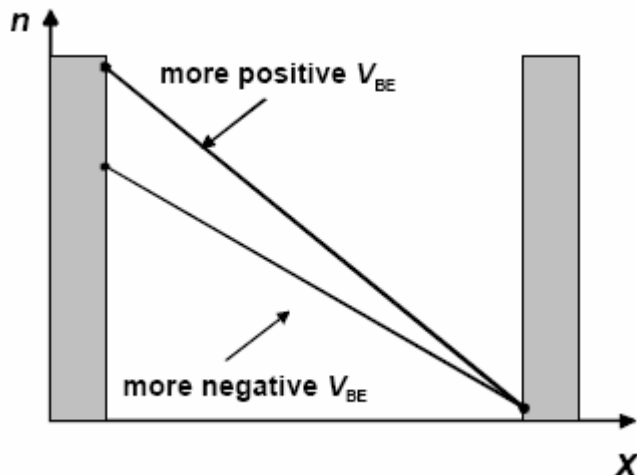
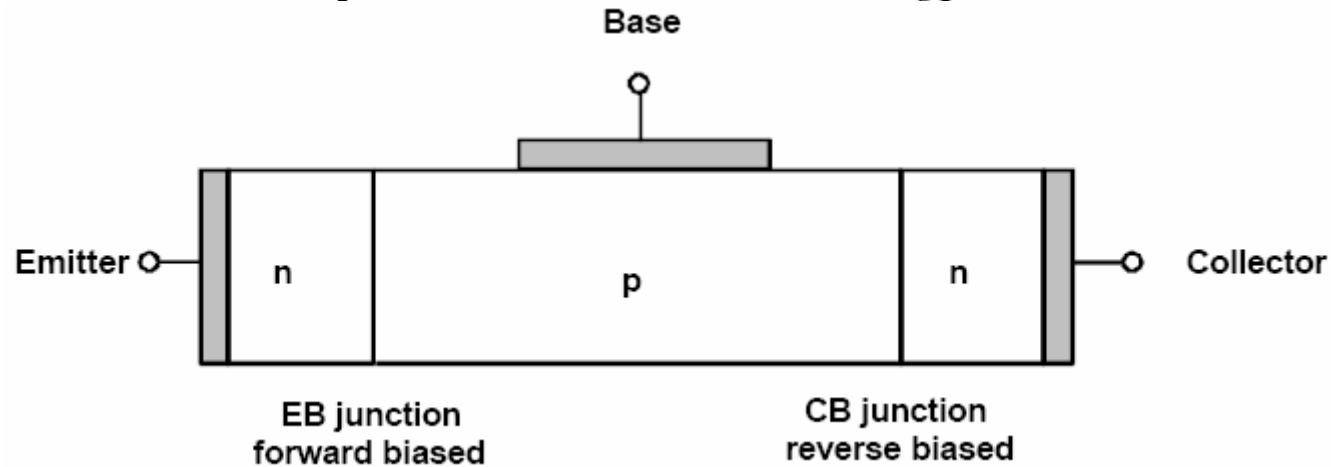

Bipolar transistors

- BJT
 - same material for emitter and base
 - EB junction is a homojunction
- HBT
 - different materials for emitter and base
 - EB junction is a heterojunction
 - emitter: wider bandgap
 - base: more narrow bandgap

How to Make a Transistor Fast ?

An RF transistor has to react as fast as possible on a variation of the input signal

FET – gate voltage V_G

**Bipolar Transistor – base voltage V_B
(base current I_B)**

- Material Issues

Most important: Fast carriers

- **The charge distribution in the active region of the transistor has to be changed.**
- **To achieve this we have to consider**
 - Transistor Design**
 - Small active region of the transistor.**
 - Critical dimension – FET: gate length L**
 - Bipolar: base thickness (width) w_B**

How to Make a FET Fast ?

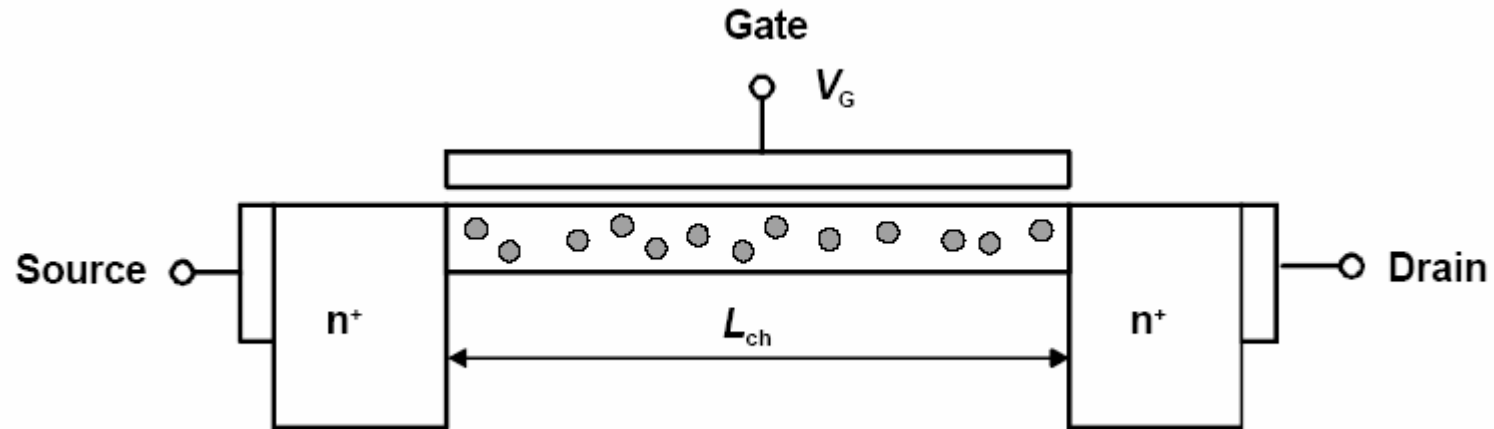

Design:

- short channel (small L_{ch})
- fast carriers (n-channel)

Material:

- fast carriers
(high mobility, high velocity)

How to Make a Bipolar Transistor Fast ?

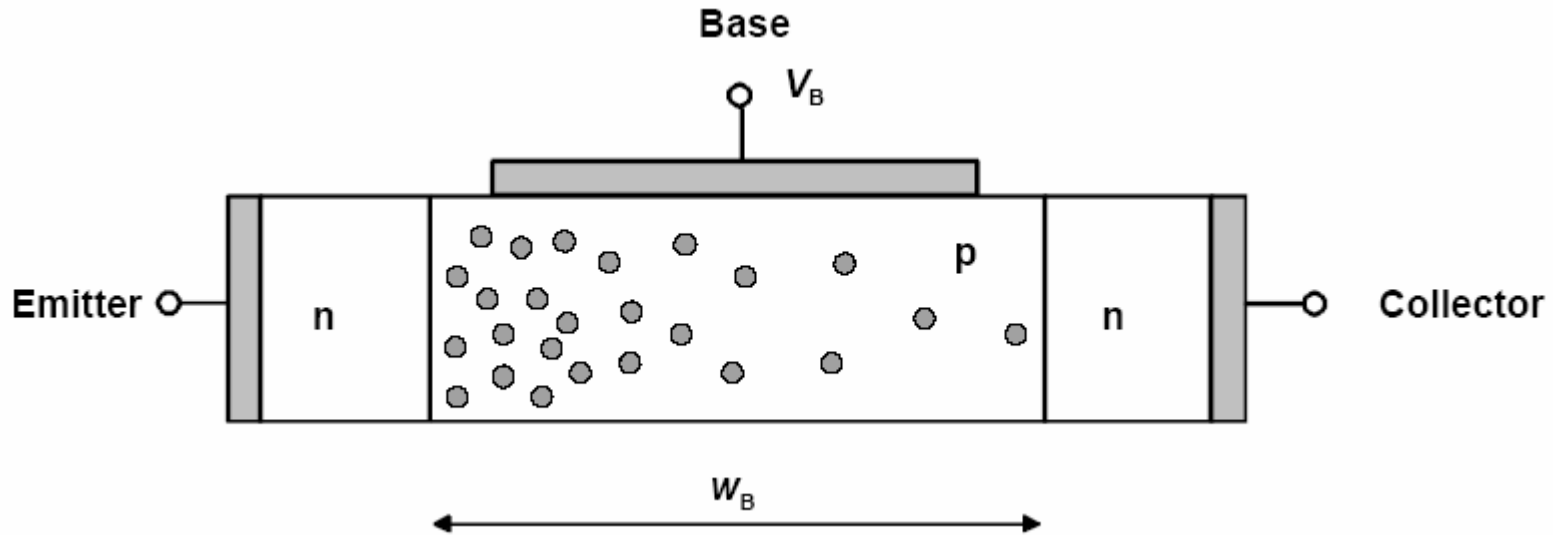

Design:

- narrow base (small w_B)
- fast carriers (npn)

Material:

- fast carriers
 - high mobility
 - high velocity
- high diffusivity

RF Transistor FOM (Figures of Merit)

The two most important features of a transistor are:

- its ability to amplify (important for analog and RF electronics)
- its ability to act as a switch (important for digital electronics)

Important Figures of Merit (FOMs) of RF transistors



RF power transistors

- Gain (power gain, current gain)
- Frequency limits f_T and f_{max}
- Output power
- ...

RF low-noise transistors

- Gain
- f_T and f_{max}
- Minimum noise figure
- ...

FOMs – Power Gains

Power Gain
General definition:

$$G = \frac{P_{out}}{P_{in}}$$

Microwave electronics - several power gain definitions.

Frequently used are:

- Maximum stable gain *MSG*
- Unilateral power gain *U*
- Maximum available gain *MAG*

Example: Definition of *U*

Power gain of a two-port having no output-to-input feedback, with input and output conjugately impedance matched to signal source and load, respectively.

$$U = \frac{|y_{21} - y_{12}|^2}{4 [\operatorname{Re}(y_{11}) \operatorname{Re}(y_{22}) - \operatorname{Re}(y_{12}) \operatorname{Re}(y_{21})]}$$

Power gains are frequently given in dB:

$$\text{Power Gain [dB]} = 10 \log(\text{Power Gain})$$

FOMs – Current Gain and Noise Figure

Current Gain

General definition:

$$|h_{21}| = \left| \frac{i_2}{i_1} \right| = \left| \frac{y_{21}}{y_{11}} \right|$$

Current gain in dB

$$|h_{21}| [dB] = 20 \log_{10} |h_{21}|$$

Noise Figure

NF describes the noise generated in the transistor. Should be as small as possible and is always above 0 dB in real transistors.

For optimum matching and bias conditions, **NF** reaches a minimum - the minimum noise figure NF_{\min} .

$$NF [dB] = 10 \log \frac{P_{Si}/P_{Ni}}{P_{So}/P_{No}}$$

2:

FOMs – The Characteristic Frequencies f_T and f_{max}

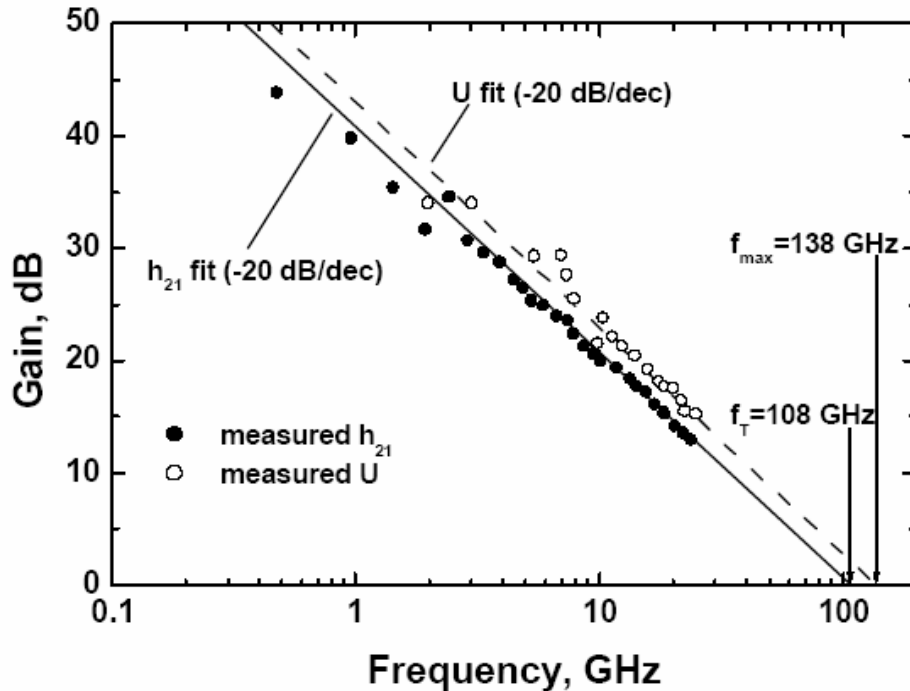

Measured h_{21} and U of a GaAs MESFET
After K. Onodera et al., IEEE Trans. ED 38, p. 429.

h_{21} and U roll off at higher frequencies at a slope of -20 dB/dec.

Cutoff Frequency f_T

Frequency, at which the magnitude of the short circuit current gain h_{21} rolls off to 1 (0 dB).

Maximum Frequency of Oscillation f_{max}

Frequency, at which the unilateral power gain U rolls off to 1 (0 dB).

Attention: Frequently f_{max} is NOT extrapolated from measured U , but from measured MAG or MSG !

Check before working with published f_{max} values!

FOMs – The Characteristic Frequencies f_T and f_{max}

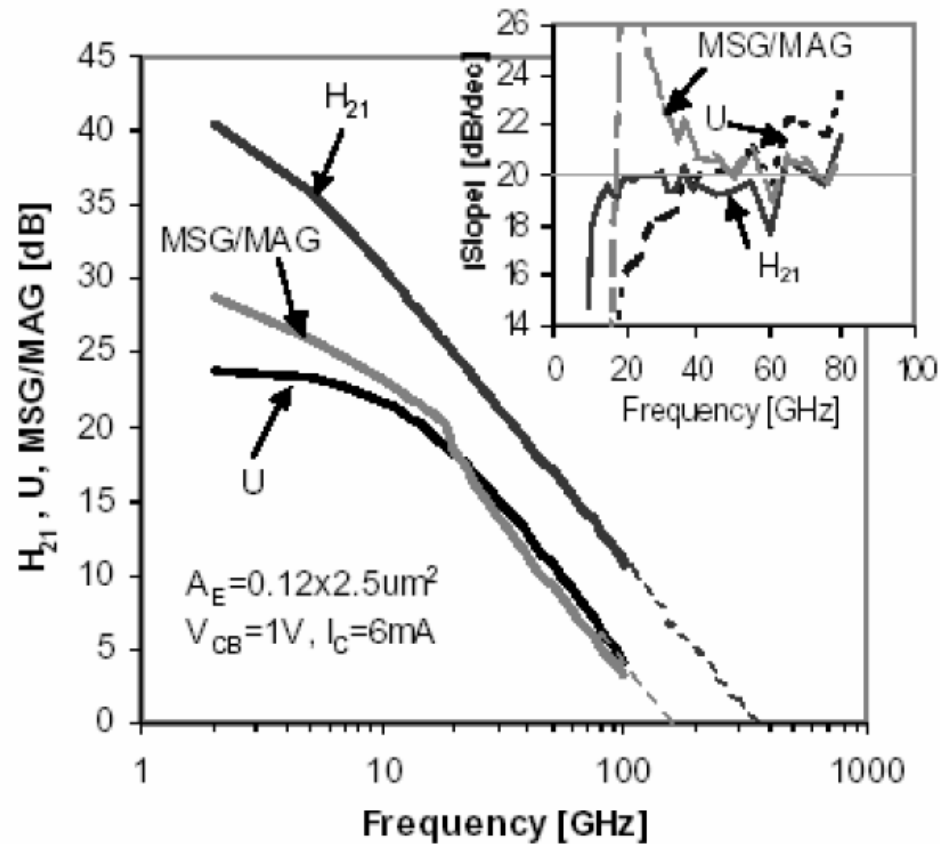

Measured h_{21} , MSG, MAG, and U of a SiGe HBT
 Ref.: J.-S. Rieh et al., IEDM 2002.

FOMs – The Importance of f_T and f_{max}

A frequently asked question:

Is the extrapolation of h_{21} and U with -20dB/dec actually useful?

The answer is: definitely YES !

1. P. Greiling (1984)

"For those of us associated with this technology, this measurement problem always seems to exist. We are in a catch 22 situation in which we are developing circuits for instruments that are needed to measure the circuits we are developing."

2. If we know the extrapolated f_{max} we find the power gain U at any frequency according to:

$$U(f) = -20 \log f + 20 \log f_{max}$$

3. Using f_T and f_{max} we can compare the RF potential of different transistors reported somewhere in the literature.

FOMs – f_T and f_{\max} vs f_{op}

Rule of thumb

$$f_T \sim n \times f_{\text{op}}, f_T \sim f_{\max}$$

- Low-noise transistors: $n \sim 10$ (conservative) , i.e., f_T should be around $10 \times$ the operating frequency f_{op} of the RF system in which the transistor is to be used.
- Power transistors: $n \sim 5$.

What does this mean?

If $n = 10$ and $f_T = f_{\max}$, we have 20 dB unilateral power gain U at f_{op} . Note that U is the upper limit for the power gain a transistor can achieve. The actual gain in a realistic circuit environment, e.g. G_a for minimum noise, will be several dB lower.

Examples:

GaAs MESFET: $f_{\max} = 70$ GHz

$U @ 12$ GHz = 15.3 dB, $G_a @ 12$ GHz = 11 dB

AlGaAs/GaAs HEMT: $f_{\max} = 50$ GHz

$U @ 12$ GHz = 12.4 dB, $G_a @ 12$ GHz = 9 dB

AlGaAs/GaAs HEMT: $f_{\max} = 120$ GHz

$U @ 18$ GHz = 16.5 dB, $G_a @ 18$ GHz = 11.6 dB

FOMs – Output Power

Amount of RF power in Watt (W) that can be delivered from a transistor to the load.

General definition:
$$P_{out} = \frac{1}{T} \int_0^T R_L i_L^2$$

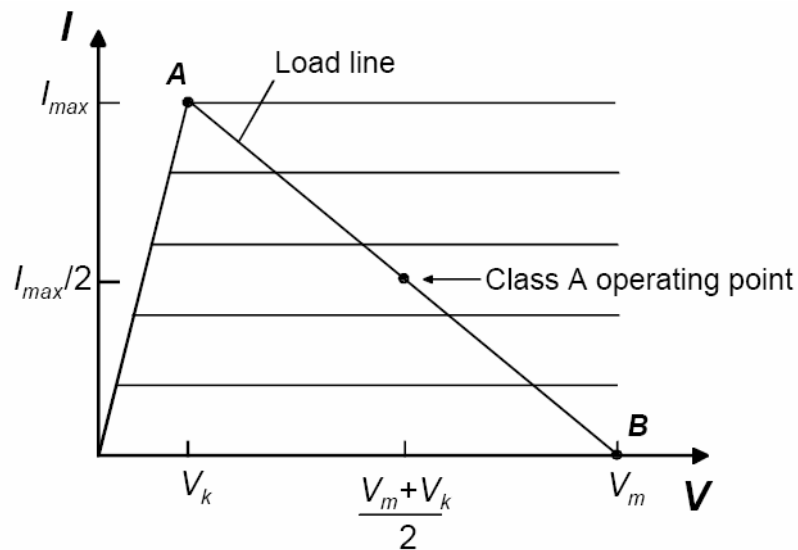

Class A amplifier

$$P_{out} = \frac{I_{max} (V_m - V_k)}{8}$$

FOMs – Output Power

The output power is frequently given in dBm:

$$P_{out} [dBm] = 10 \log P_{out} [mW]$$

$$P_{out} [mW] = 10^{P_{out} [dBm]/10}$$

Examples:

1 mW = 0 dBm	-10 dBm = 0.1 mW
10 mW = 10 dBm	30 dBm = 1000 mW = 1 W
20 mW = 13 dBm	40 dBm = 10 W
100 mW = 20 dBm	50 dBm = 100 W

A FOM related to the output power is the output power density P_{Dout} :

- P_{Dout} in W/mm gate width (FETs)
- P_{Dout} in mW/ μm^2 emitter area (bipolar transistors)

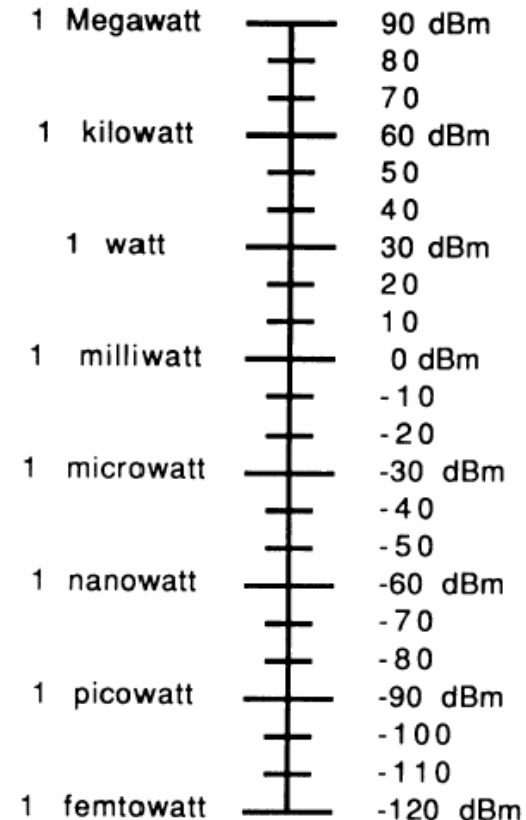

Ref.: A. W. Scott, Understanding Microwaves, J. Wiley 1993

Material Issues

Most Important for high speed (high f_T and f_{max}) and for low noise:
Fast carriers, i.e. - high low-field mobility (μ_0)
 - high peak and/or saturation velocity (v_{peak} , v_{sat})

Important for high output power:
 - high breakdown voltage, i.e. wide bandgap
 - high thermal conductivity

	Si	GaAs	In _{0.47} Ga _{0.53} As	4H SiC	GaN
E_G , eV	1.12	1.42	0.74	3.2	3.44
E_{BR} , 10^5 V/cm	5.7	6.4	4	33	44
μ_0 , cm^2/Vs	710	4700	7000	610	830
v_{peak} , 10^7 cm/s	1	2	2.5...3	2	2.5
v_{sat} , 10^7 cm/s	1	0.8	0.7	2	1.5...2
κ , W/cm-K	1.3	0.5	0.05	2.9	1.2

Data for n-type material with $N_D = 10^{17} \text{ cm}^{-3}$

Low-Field Mobility and Drift Velocity

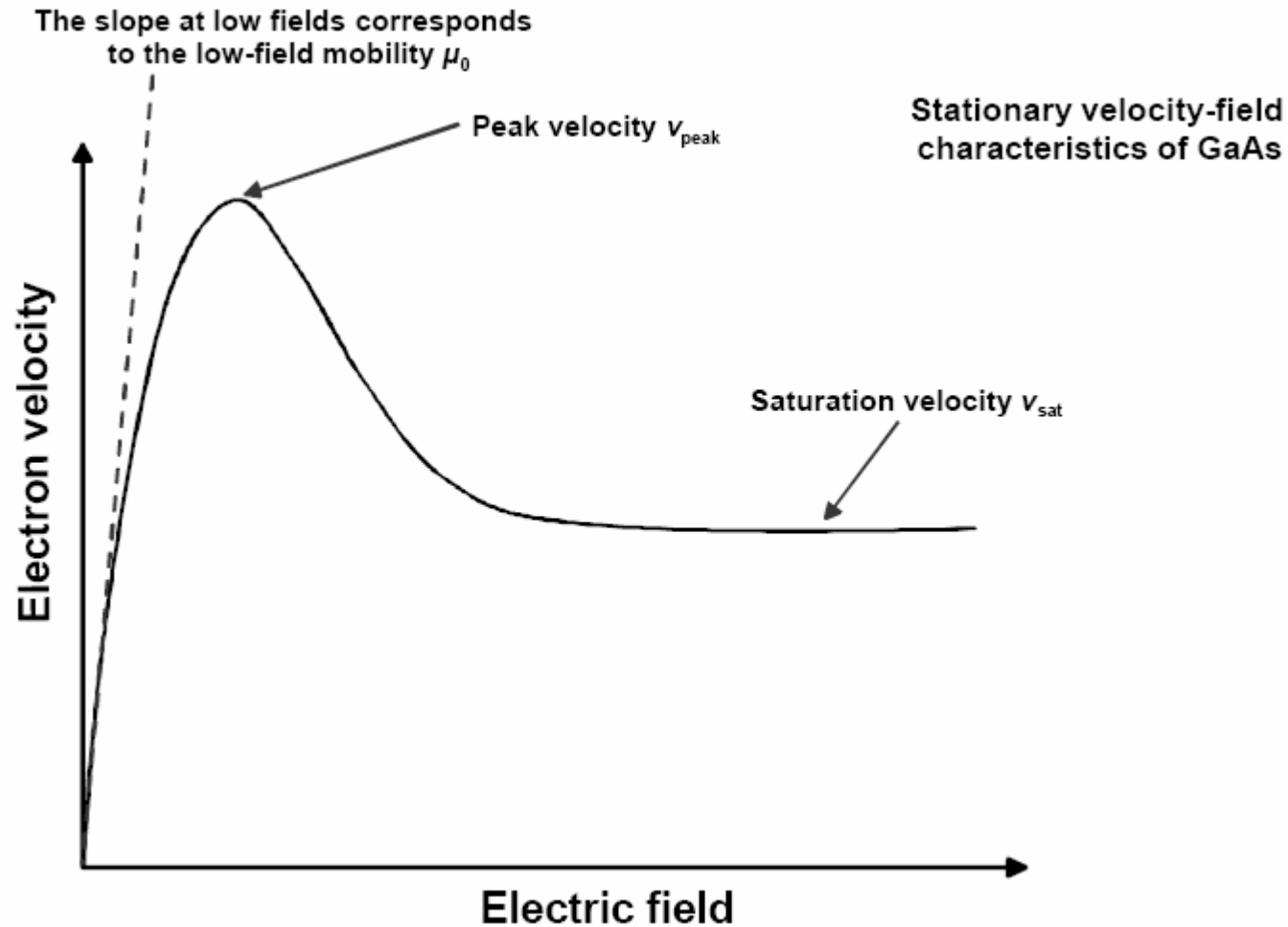

Low-Field Mobility

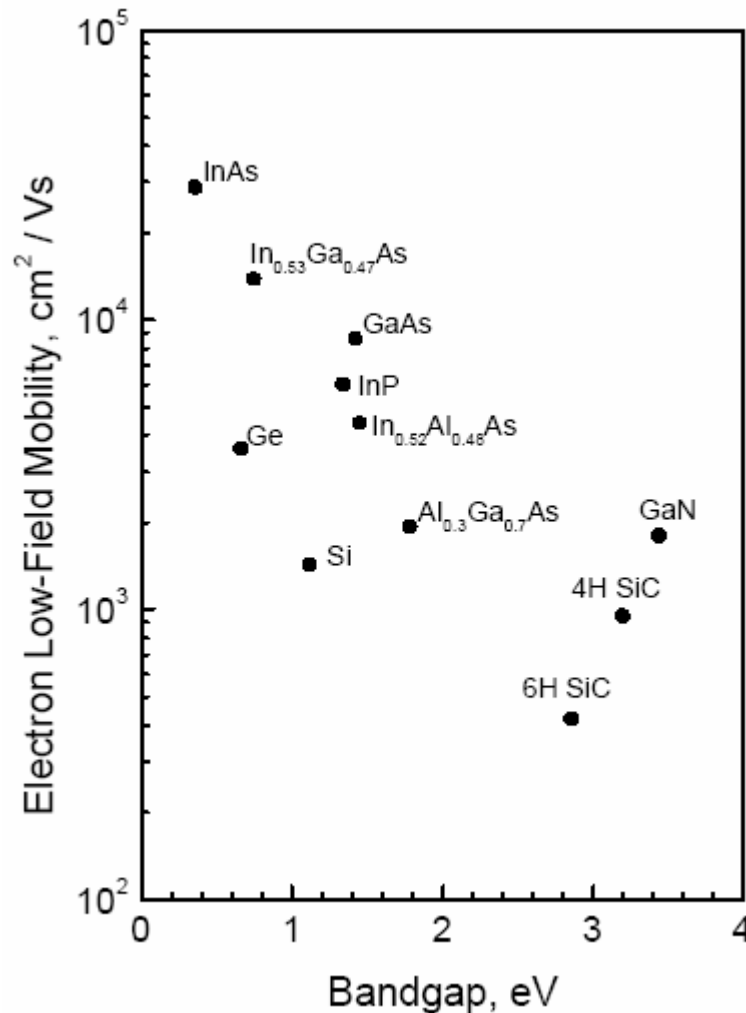

Carrier velocity at low electric field:

$$v = \mu_0 \times E$$

In any semiconductor the electron mobility is larger than the hole mobility.

Thus, for RF applications transistors where electrons carry the main current are preferred:

n-channel FETs
npn bipolars

low-field mobility of electrons
(undoped material, $T = 300\text{K}$)

Drift Velocity

Stationary velocity-field characteristics (v - E)

Si and III-V semiconductors

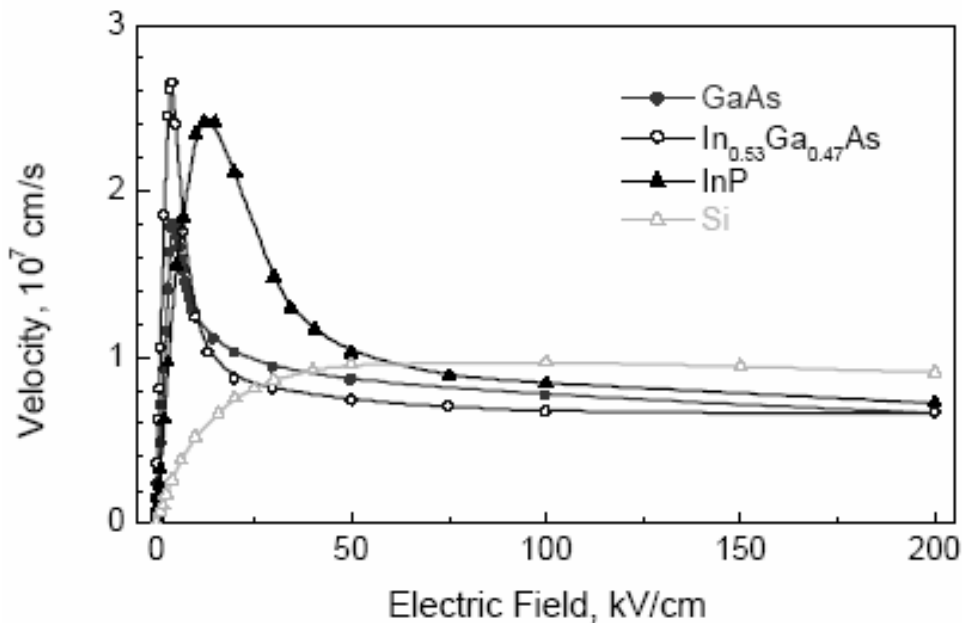

Wide bandgap semiconductors

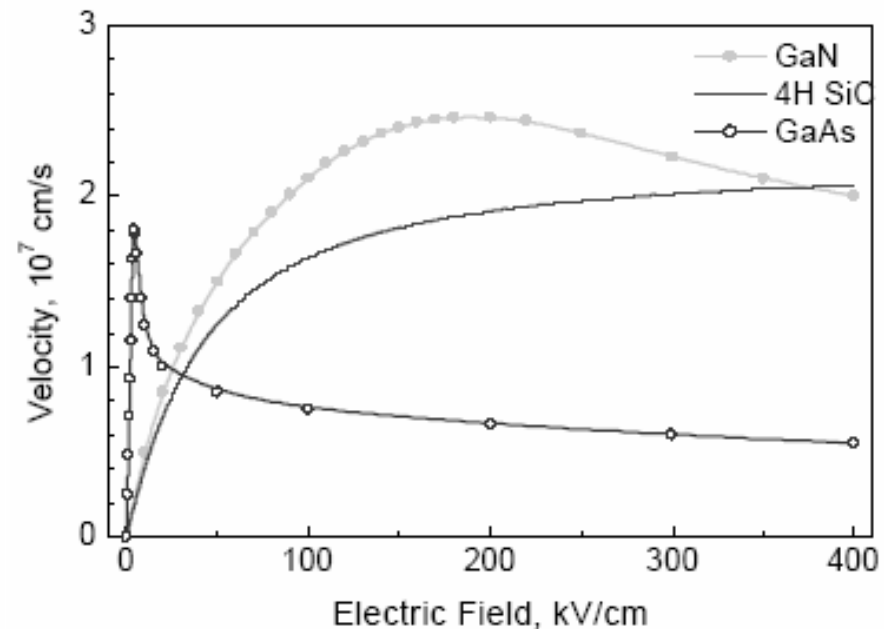

Breakdown Voltage

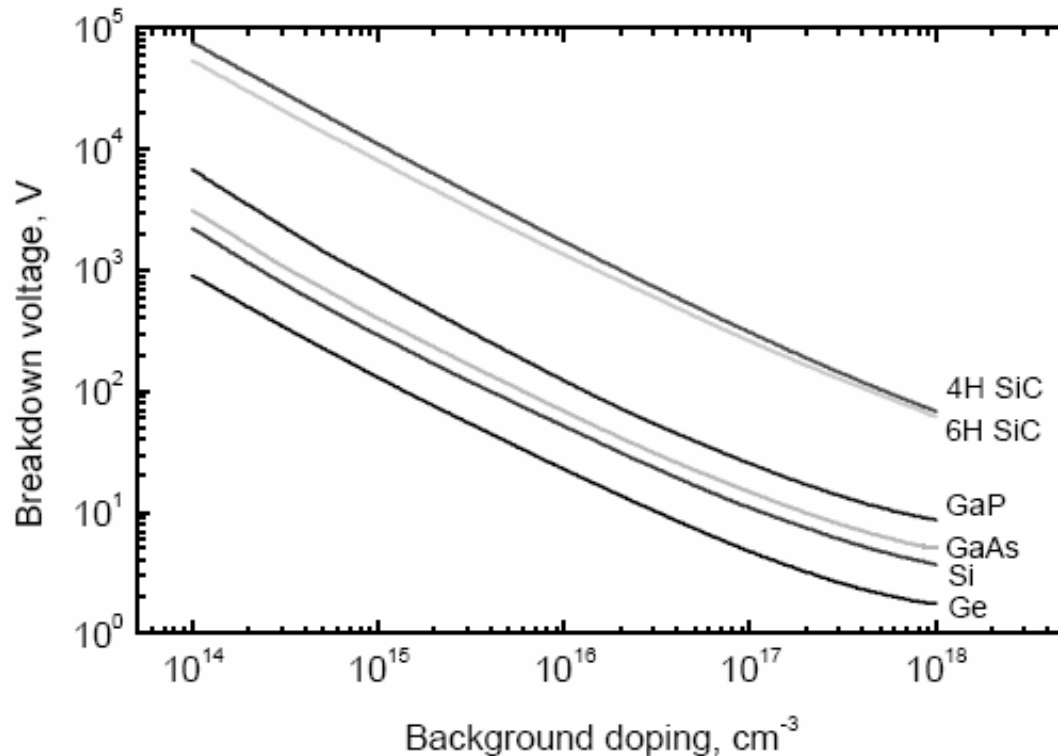

Breakdown voltage of abrupt one-sided pn junctions as a function of doping (at the low-doped side)
The breakdown voltage is closely related to the breakdown field.



Bandgap increases

4H SiC $E_G = 3.20 \text{ eV}$

GaAs $E_G = 1.42 \text{ eV}$

Ge $E_G = 0.66 \text{ eV}$

A large bandgap results in a large breakdown voltage.
For power transistors a high breakdown voltage is important.
LARGE POTENTIAL FOR WIDE BANDGAP MATERIALS!

Heterostructures

Heterostructures

- are semiconductor structures consisting of at least two different semiconductors
- are uncommon in mainstream electronics
- are frequently used in RF transistors
 - FETs: HEMTs
 - Bipolars: HBTs
- The RF transistors showing
 - the highest f_T and f_{max}
 - the highest output power densities
 - the lowest noiseare heterostructure transistors.

Therefore it is useful to discuss some aspects of heterostructures in the following.

Heterostructures

The physics exploited in RF heterostructure transistors

Most important: band offsets ΔE_C and ΔE_V

HEMTs
(here: AlGaAs/GaAs HEMT)

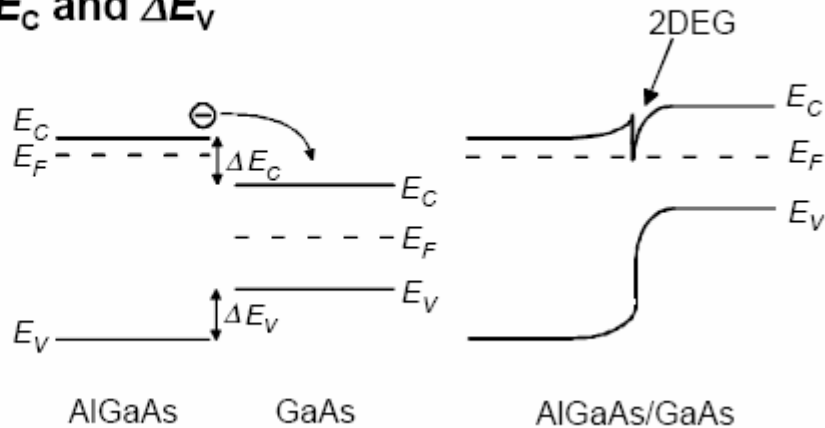

HBTs
(here: AlGaAs/GaAs HBT)

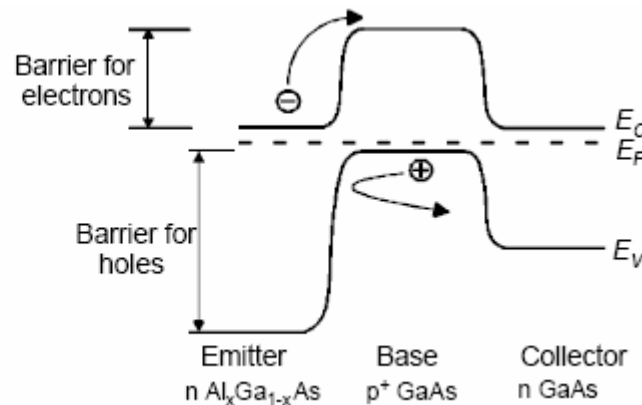

Heterostructures

Semiconductor pairs frequently used in heterostructures

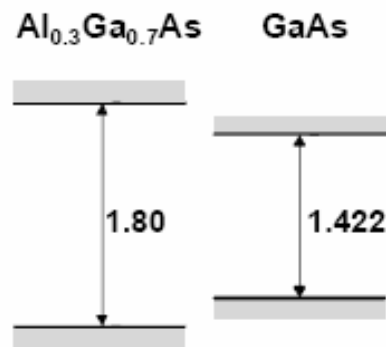

$$\Delta E_C = 0.219$$

$$\Delta E_V = 0.159$$

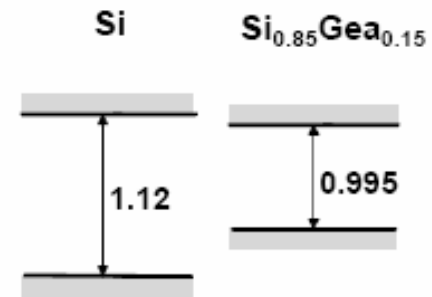

$$\Delta E_C = 0.02$$

$$\Delta E_V = 0.105$$

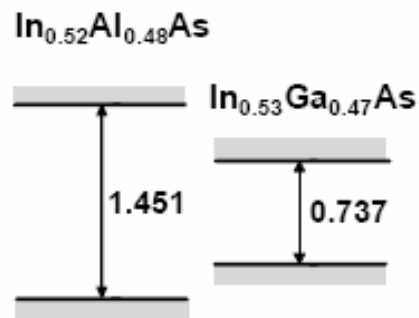

$$\Delta E_C = 0.52$$

$$\Delta E_V = 0.194$$

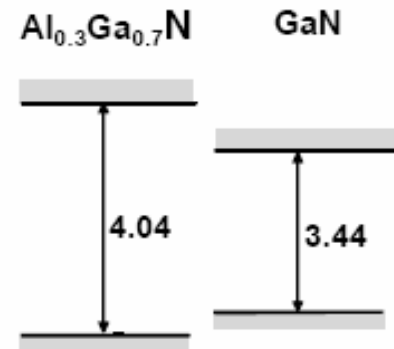

$$\Delta E_C = 0.42$$

$$\Delta E_V = 0.18$$

Bandgap vs Lattice Constant

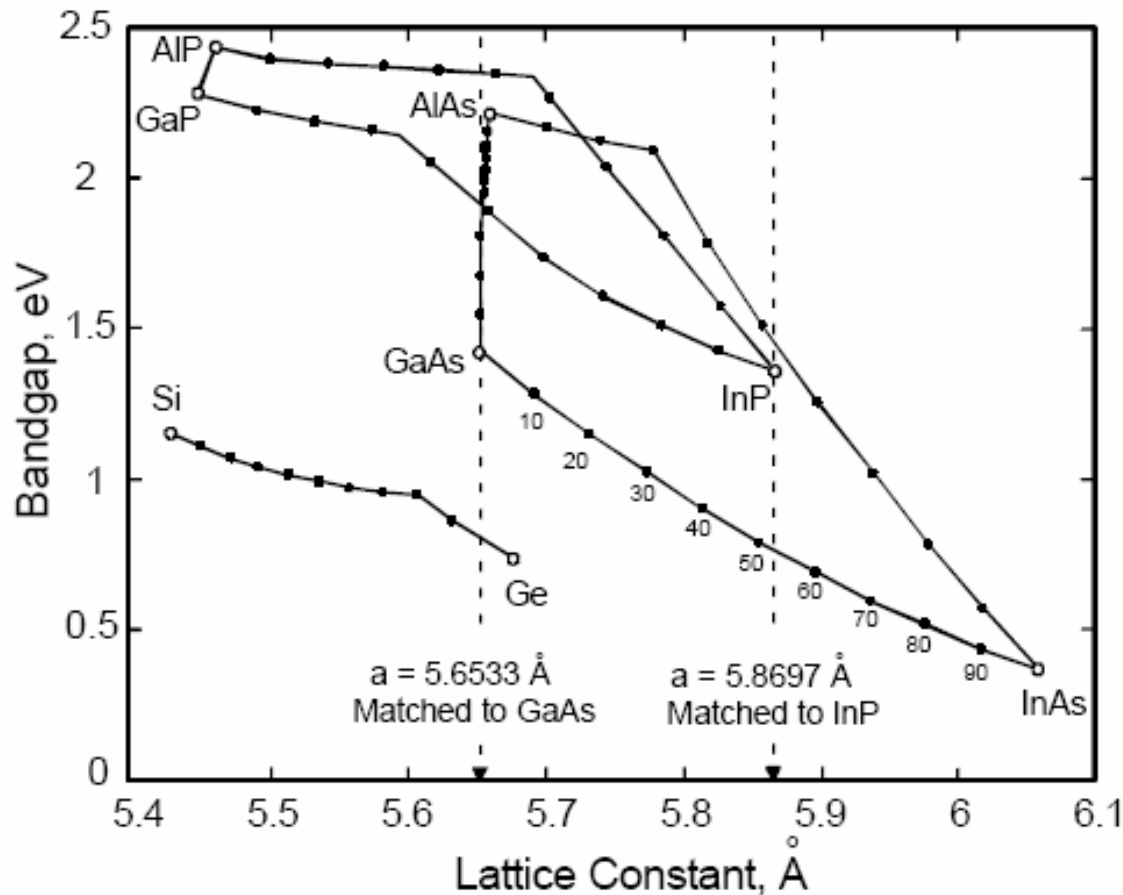

HETEROSTRUCTURES:

Lattice matched

- AlGaAs/GaAs
- $\text{In}_{0.52}\text{Al}_{0.48}\text{As}/\text{In}_{0.53}\text{Ga}_{0.47}\text{As}/\text{InP}$

Pseudomorphic (strained)

- AlGaAs/ $\text{In}_x\text{Ga}_{1-x}\text{As}/\text{GaAs}$
- $\text{In}_{0.52}\text{Al}_{0.48}\text{As}/\text{In}_x\text{Ga}_{1-x}\text{As}/\text{InP}$
- Si/ $\text{Si}_{1-x}\text{Ge}_x$
- $\text{Al}_x\text{Ga}_{1-x}\text{N}/\text{GaN}$

Pseudomorphic Heterostructures

Example: InGaAs/GaAs

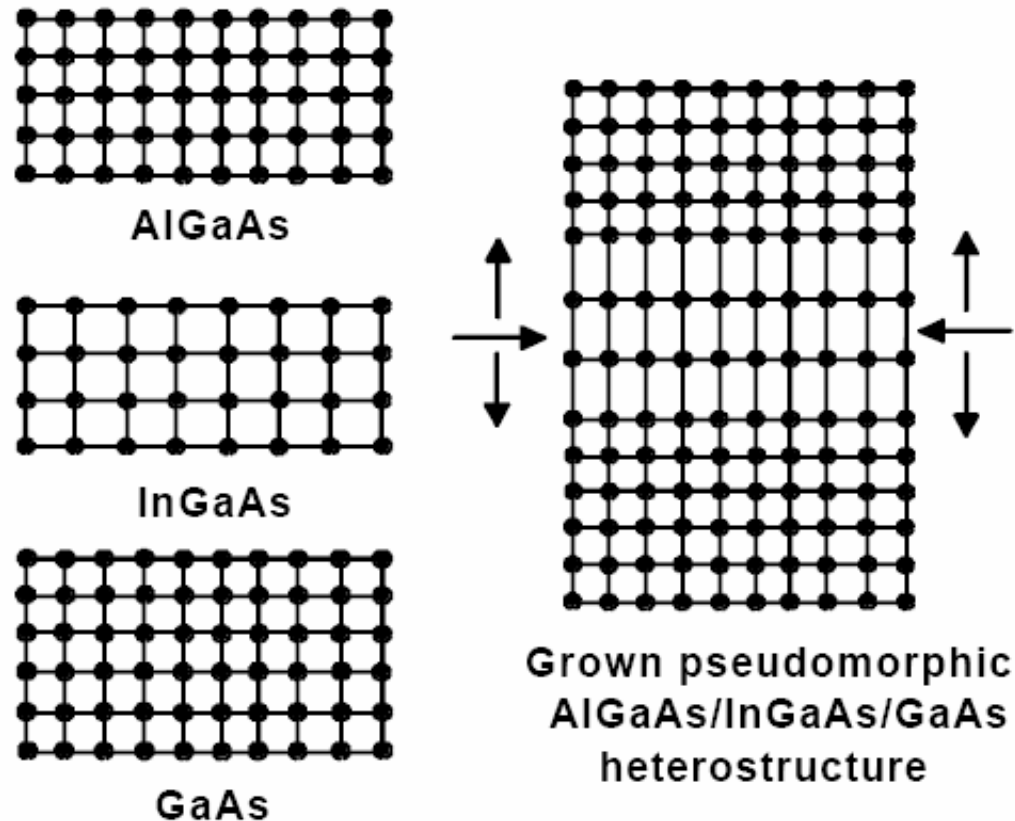

The InGaAs layer is **STRAINED**
(provided the critical thickness is not exceeded)

Critical Thickness

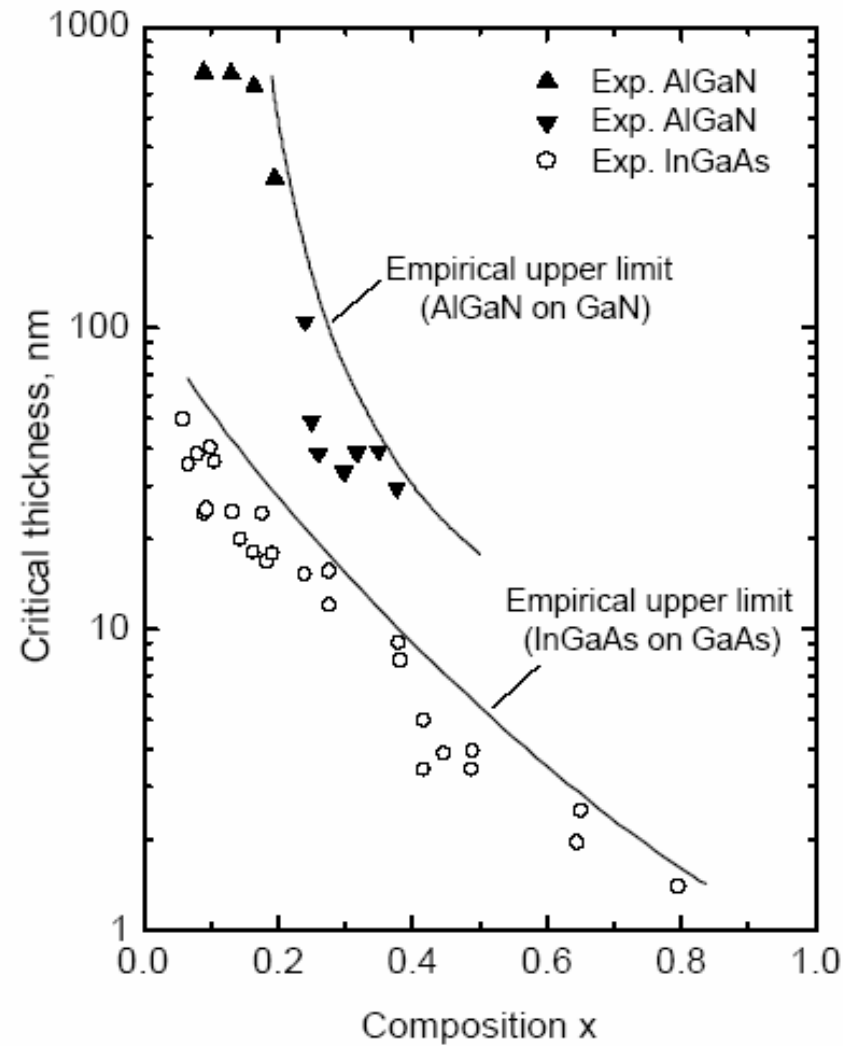

Properties of 2DEGs

Heterojunction Type	μ_0 , cm ² /Vs	n_s , cm ⁻²	ΔE_G , eV	ΔE_C , eV
Al_{0.3}Ga_{0.7}As/GaAs	5400	1.4 x 10 ¹²	0.38	0.22
Al_{0.3}Ga_{0.7}As/In_{0.2}Ga_{0.8}As	6400	2.2 x 10 ¹²	0.58	0.41
In_{0.52}Al_{0.48}As/In_{0.53}Ga_{0.47}As	10 000	3.0 x 10 ¹²	0.71	0.52
Al_{0.3}Ga_{0.7}N/GaN	1 400	1.3 x 10 ¹³	0.6	0.42

Common III-V heterostructures:

- more In in the channel layer leads to higher mobility μ_0
- larger ΔE_C causes a higher sheet concentration n_s

Interesting for AlGaN/GaN:

- lower mobility than III-V's
- rather moderate ΔE_C but extremely high n_s - WHY ?
- reason: polarization effects

History and Evolution of RF Transistors

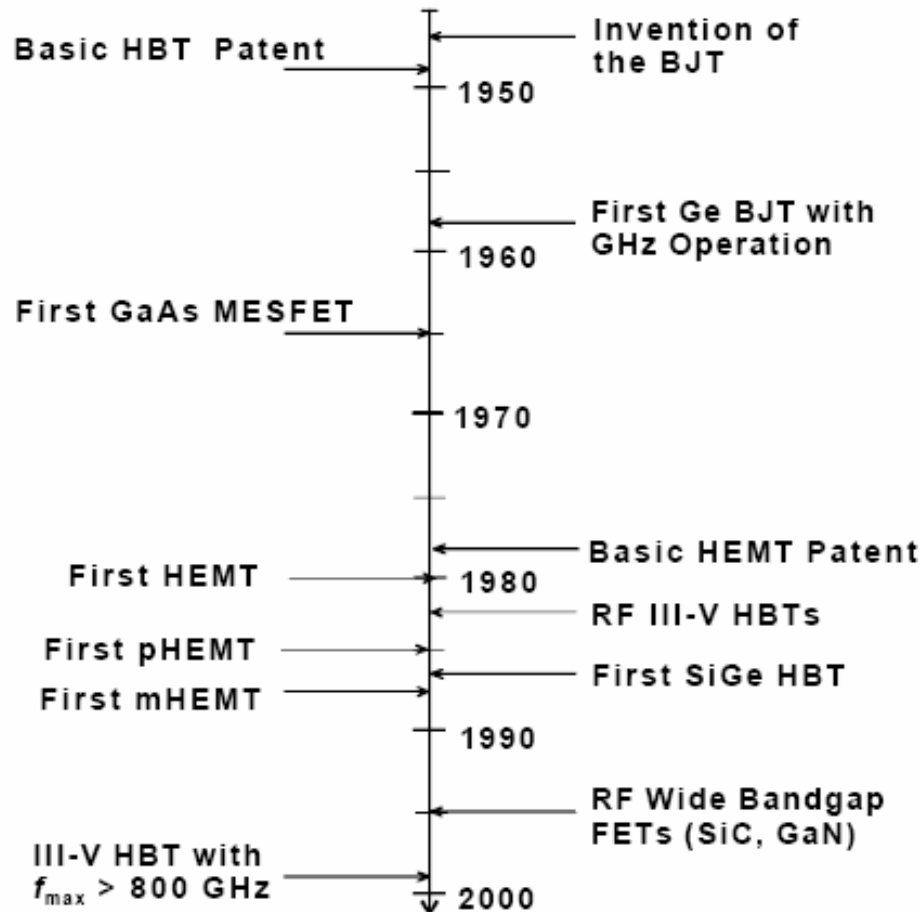

1980 Only two types of RF transistors available:
 Si BJTs (f_{op} up to 4 GHz)
 GaAs MESFETs (f_{op} 4-18 GHz)

2004 Many different types of RF transistors available:
Bipolar: Si BJTs, SiGe HBTs, III-V HBTs
FET: GaAs MESFETs, III-V HEMTs, Wide Bandgap HEMTs, Si MOSFETs

Frequency Limits

III-V FETs: $f_{max} > 600$ GHz
 III-V HBTs: f_{max} 1.1 THz

Trends in the Evolution of RF Transistors

Important Trends:

- **Continuous improvement of transistor performance**
 - Continuous increase of the frequency limits f_T and f_{max}
 - Increase of the output power at a given frequency
 - Decrease of the minimum noise figure at a given frequency
- **During the last 10 years: Shift of the applications of RF systems from defense and space applications to commercial mass markets**
 - RF is becoming mainstream
 - Most commercial applications are in the lower GHz range
- **Development of low-cost RF transistors for mass consumer markets.**
 - Growing role of Si-based RF transistors
 - For mass markets, cost is an extremely important issue – and Si technology is less expensive than any other semiconductor technology.

History and Evolution of RF Transistors

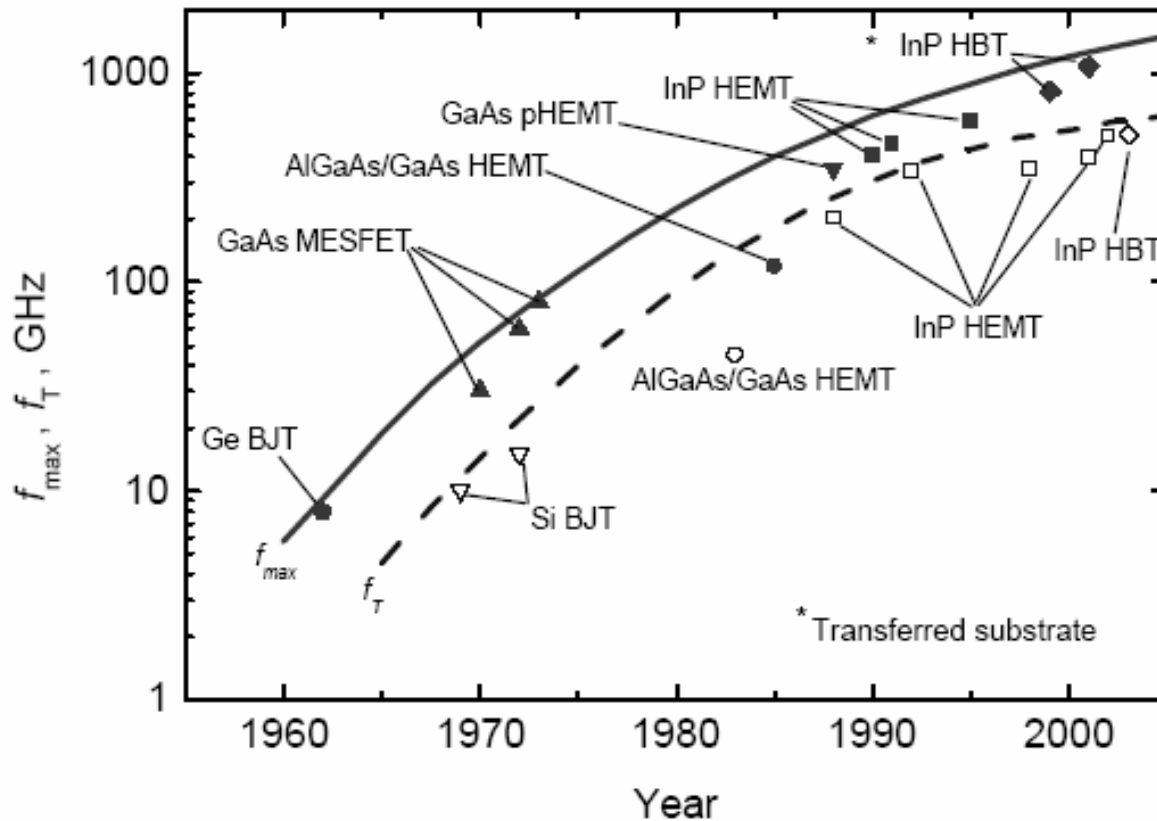

Evolution of the frequency limits of RF transistors

Continuous increase of the frequency f_T and f_{max} .

History and Evolution of RF Transistors

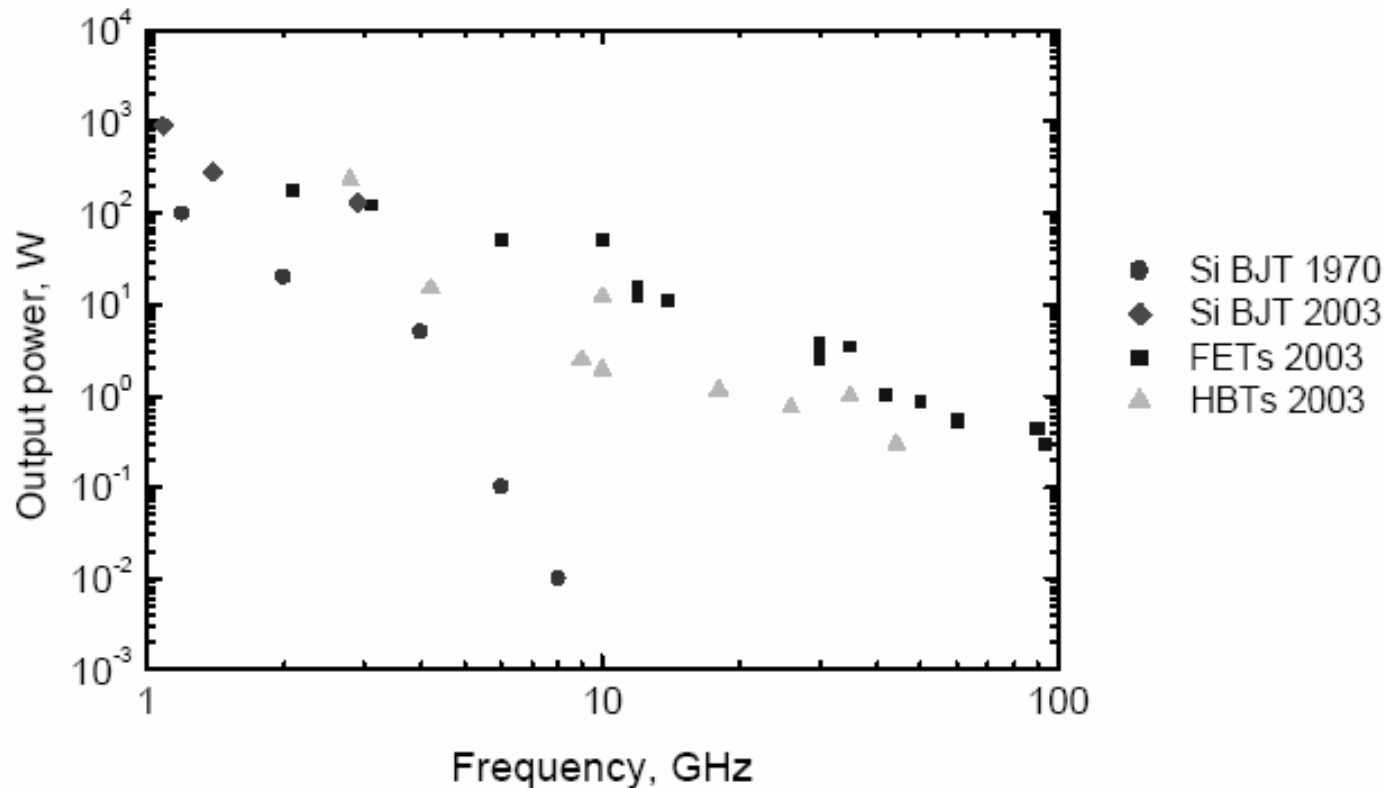

Output power of RF transistors vs frequency

1970: Only Si power BJTs for RF available

2003: Si BJTs, different HBT types, and different FETs types available

History and Evolution of RF Transistors

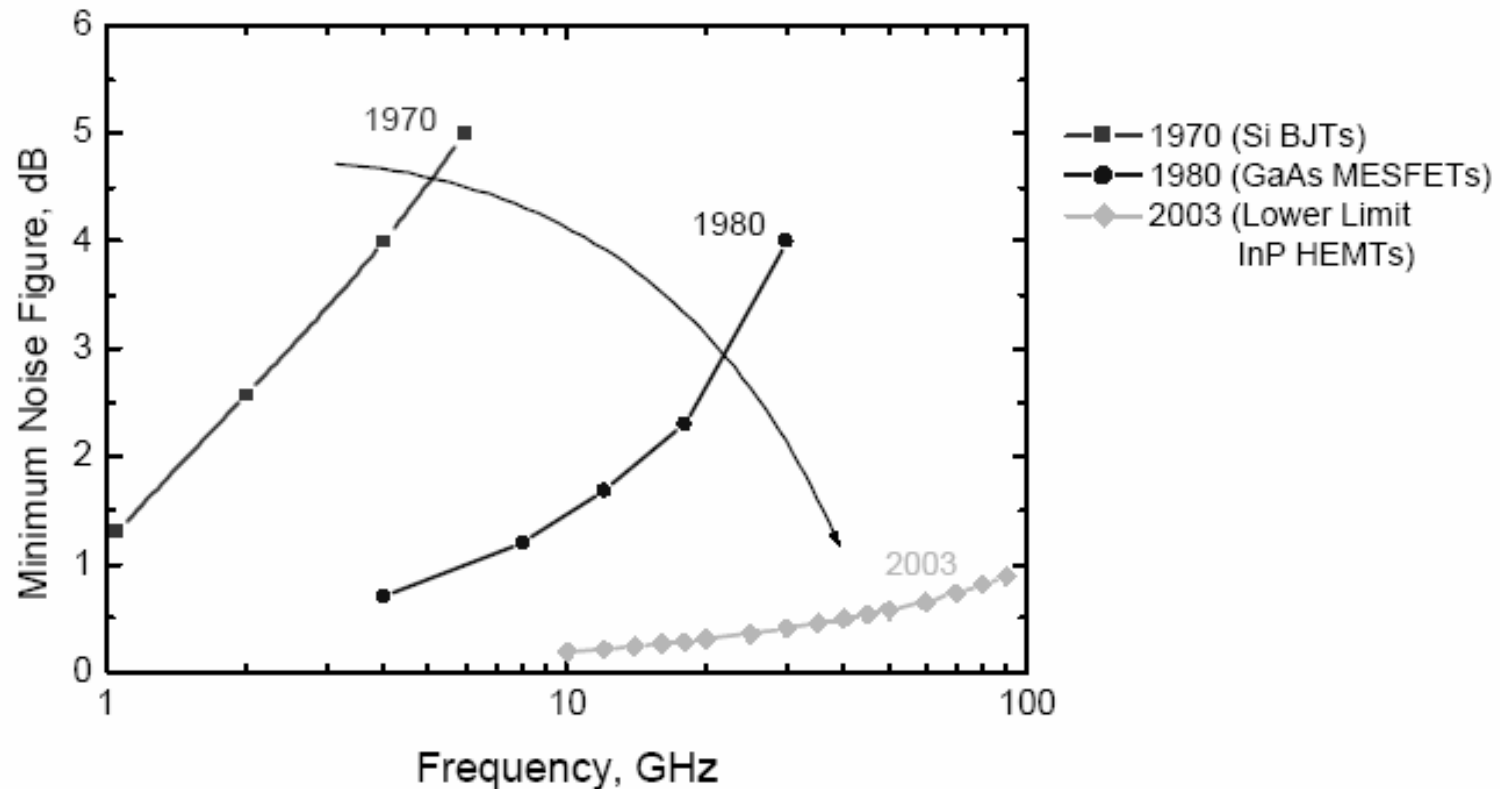

Minimum noise figure of low-noise RF transistors vs frequency

1970: Only Si power BJTs for RF available

1980: GaAs MESFET least noisy

2003: InP HEMTs least noisy