

## Panel Session on

# Green Wireless Technology

# Networked Radio Frequency IDentification (NRFID) and related green technologies

## Panelist:

Luca Roselli; Dept. of Electronic Engineering and Information, Univ. of Perugia, Italy



# Summary

---

- NRFID (Networked Radio Frequency IDentification): motivations
- RFID basics and application
- NRFID Technology
- NRFID Challenges
- NRFID Advantages
- Conclusion



# Networked RFID: motivations

---

- “objects” networking (internet of things)
- networking and “green solutions”
- reduction of power budget
- green related technologies



# RFID basics

- RFID is an ADC (Automated Data Collection) technology that uses radio frequency waves to transfer data between a reader and a movable item to identify, categorize, track... On demand.
- RFID is fast, reliable, and does not require physical sight or contact between reader/scanner and the tagged item

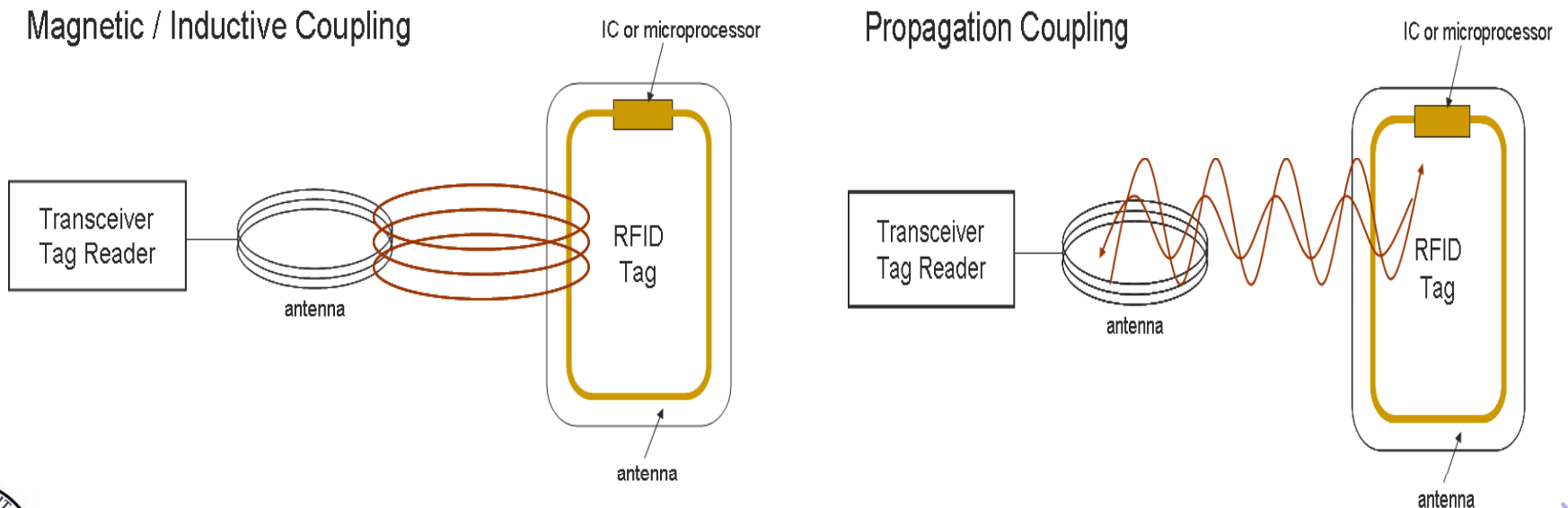

# Frequency Ranges

- Radio frequency in this context ranges from 118KHz through microwave frequencies up to 5.8GHz , particular bands being:
  - Low Frequency (LF) <135 KHz
  - High Frequency (HF) 13.56 MHz
  - Ultra High Frequency (UHF) 0.3 - 1.2 GHz
  - Microwave 2.45 - 5.8 GHz
  - mm-wave, likely in the future



# RFID applications



Transport and Logistics

Tracking

Library systems



Shopping

Contactless payment systems

Supply-chain Management and Manufacturing

Defense/Security

Sports/leisure

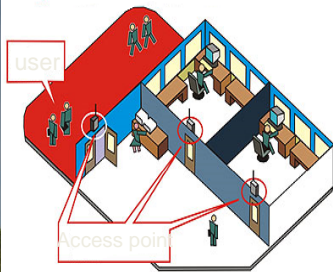

Access control

Personal Welfare and safety

## Applications



Smart homes, smart cars, smart lifestyles



Medical and pharmaceutical



sensor (car , fridge, ..)





## Applications:

RFID is already used in transport and supply chain management and applications areas are growing. A wide variety of emerging applications is given below :

### 1. Business applications, e.g.

- a Transport and Logistics
- b Access control
- c Supply-chain Management
- d Manufacturing
- e Medical/Pharmaceutical Applications

### 2. Public Sector applications, e.g.

- a E-government
- b Defense/Security
- c Library systems

### 3. Consumer applications, e.g.

- a Personal Welfare and safety
- b Sports/leisure
- c Shopping
- d Smart Lifestyles

### 4. Medical and Pharmaceutical

- a in hospitals, enables fully automated solution for information delivery at patient bedside
- b Using WLAN, tags embedded in medication or patient bracelets can provide fast access to a remote records database.
- c RFID can also reduce pharmaceutical counterfeiting.

### 5. e-government, defense & security

- a Many authorities considering RFID for making services more efficient, secure.
- b Thwarting fraud, through tracking people (e.g. passports and /or money, and storing this information in large databases.
- c This of course raises even more privacy concerns.

### 6. Retail applications & mobile commerce

- a Wal-Mart first/largest retailer to deploy RFID for item-based tagging.
- b First advantage in future for customers is the speedier checkout.
- C Contactless payment systems on the rise.

### 7. Smart homes, smart cars, smart lifestyles

- a RFID deployment in combination with sensor technologies to develop a sensor-enabled smart car or fridge.
- b RFID spaces for physically challenged
- c RFID making life easier to manage, and reducing number of mundane daily tasks.

# RFID enables O2O and O2H comm.

RFID enables objects to connect through **networks**

“**object to object**” and “**object to human**” communication

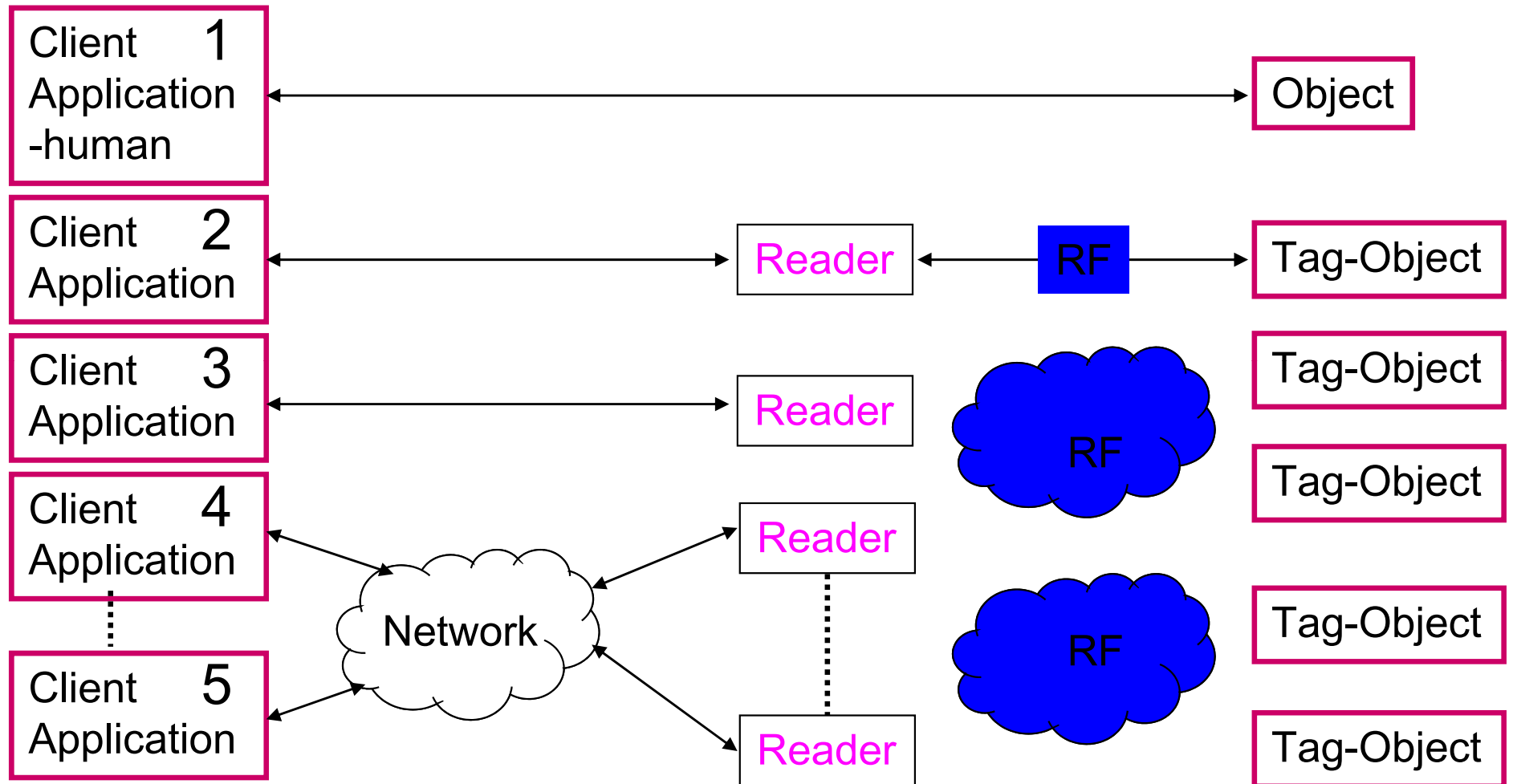

# Networked Radio Frequency Identification

- RFID is a generic term for technologies that use radio waves to remotely retrieve, identify and store data.
- RFID is a combined term with RF and ID where RF means a wireless communication technology and ID means identification information of tag. So it is said that **RFID** is theoretically a **wireless networking technology** to transmit identified information stored at an electronic memory space.
- RFID systems can either be networked or stand-alone. The data collected by an RFID system is stored in a database which can be on-line or off-line depending on its use of the data communication networks.

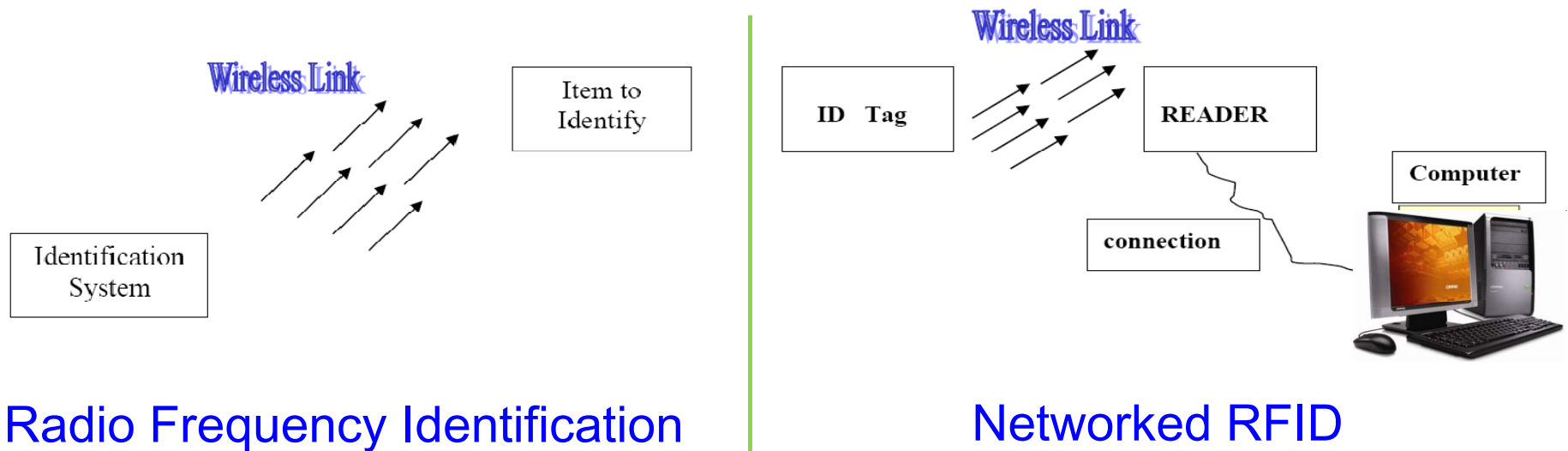

# anywhere, anytime, anyone and ANYTHING

- It is often talked about anytime, anywhere connection of anyone but it can go still further like anywhere, anytime, anyone and anything.
- This is the vision underlining the concept of network of things or objects where each item as its own identity in cyberspace.
- At present internet connects computers to one another but networked RFID will enable connection of computers to things which is a complete new dimension to imagine.



## Networked Radio Frequency IDentification



# NRFID - CHALLENGES

---

In the world of connected objects, the goal is to have **efficient** RFID networks



**Right information** to the **right application** at the **right time**



Make enterprise-management systems **event-driven**



# NRFID - CHALLENGES

- Reader Infrastructure Network Problems



- Tag filtering at “air level”
- Multiple application problem: create/manage access rules at the readers
- Security/Authentication
- Reader Device Discovery and Configuration
- Reader Device Management

**3Rs -> Right information to Right Application at the Right Time**

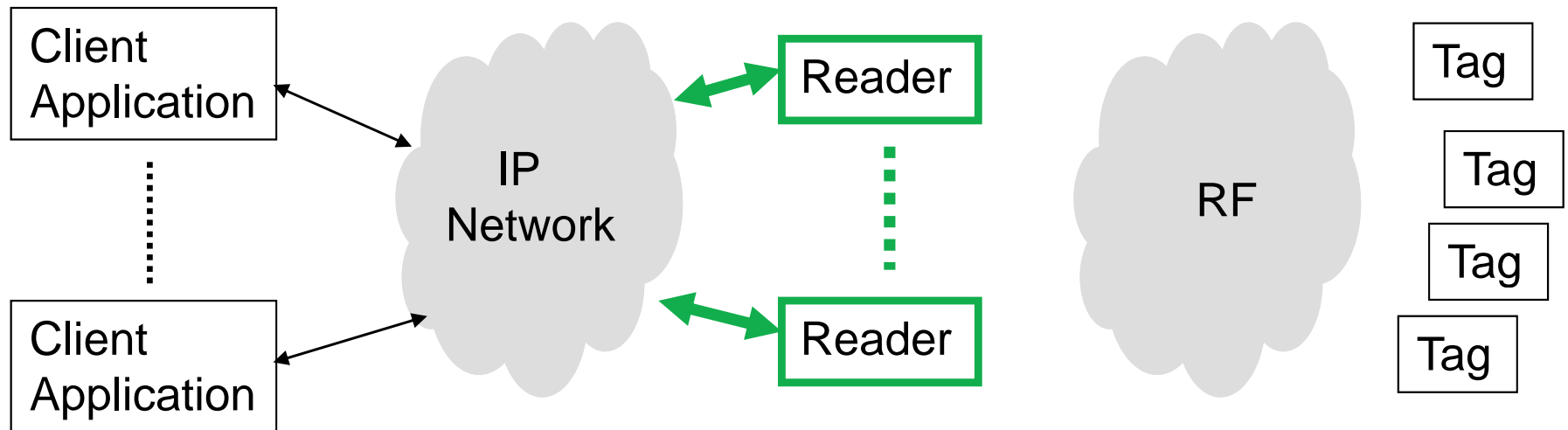



## SoE6

An RFID network generates a continuous stream of data. Because of its sheer volume, this data needs to be handled very carefully.

In the world of connected objects, the goal is to have efficient RFID networks that provide the right information to the right application at the right time (the "3 Rs") and make enterprise-management systems event-driven.

An [RFID tag](#) is read as it enters the vicinity of an RFID [interrogator](#), and an RFID event is generated and routed over the network. At the lowest level, the event is just a tag ID, a [reader](#) ID and the time last seen. The broadcasting of each RFID event to all parties creates too much [noise](#), however, and not every application needs a particular event. The result is more traffic on the network, and applications get bulkier and slower because they have to process every event.

: If a forklift carrying tagged material passes through a reader's vicinity three times, three different events are generated for the same tag, even though only one is relevant to the application

. This might happen if an operator were to overlook something and back up the forklift to correct the mistake. Two of the three resultant reads would be spurious and would need to be discarded, either by the network or by the applications consuming the data. The later choice would increase traffic on the RFID network. Applications need logic to sieve out such spurious events, making them bulky

## Diapositiva 13

---

**SoE6**

questa slide va cancellata essendo riassunta nella slide 11

School of ECE; 08/01/2010

# NRFID Vs Green Electronics

## ■ ENERGY CONSUMPTION IMPROVEMENTS

- Power reduction due to the power saved during the RFID tag “sleep mode” – RFID is inherently an “on demand” approach.
- Power reduction due to the fact that tags can be interrogated only when information is required
- Power reduction due to the fact that network traffic can be reduced by filtering events at reader level, before they access the network
- Adaptability to power source capacity by duty cycle optimization (important for the efficient utilization of power scavengers and avoidance of batteries)



# NRFID Vs Green Electronics

- RFID as “GREEN TECHNOLOGY” :

- Inkjet printed tag antennas on paper substrate

- Inkjet printing of circuits on paper substrate

- Recent studies on organic thin film solution for diodes and transistor fully printed on paper

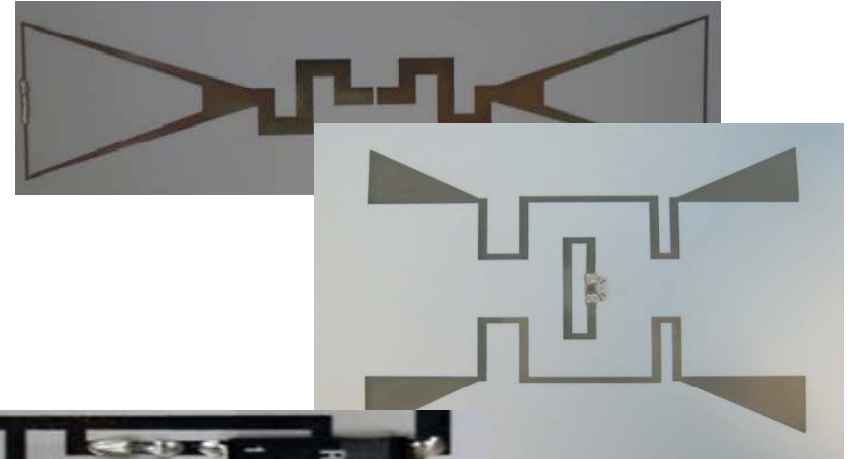

# Conclusion

---

- NRFID is a powerful tool for capturing data, but it takes still a complete system of RFID readers, networks, mobile computers and software to create useful information, and new processes to take advantage of it.
- The implementation of RFID networks driven by target applications will lead to better business intelligence, faster and cheaper event-driven enterprise applications and more manageable and sustainable software architecture.
- Smart RFID networks can provide such application-level services as location, dwell times, transit times and quantity, and also issue alerts when exceptional situations—stale and aging inventory, for example—are detected.



# Conclusion

---

- NRFID is a powerful tool for capturing data, but it takes still a complete system of RFID readers, networks, mobile computers and software to create useful information, and new processes to take advantage of it.
- The implementation of RFID networks driven by target applications will lead to better business intelligence, faster and cheaper event-driven enterprise applications and more manageable and sustainable software architecture.
- Smart RFID networks can provide such application-level services as location, dwell times, transit times and quantity, and also issue alerts when exceptional situations—stale and aging inventory, for example—are detected.

